

# PPU Mk3 for 5 kW Hall Effect Thrusters

**IEPC-2017-171**

*Presented at the 35th International Electric Propulsion Conference  
Georgia Institute of Technology • Atlanta, Georgia • USA  
October 8 – 12, 2017*

Eric Bourguignon<sup>1</sup> and Stéphane Fraselle<sup>2</sup>  
*Thales Alenia Space Belgium, Mont-sur-Marchienne, 6032, Belgium*

## I. ABSTRACT

Thales Alenia Space Belgium (ETCA) has developed and qualified the PPU Mk3, dedicated to 5kW Hall Effect Thrusters, to reply to the market demand of full electric satellites performing the Orbit Raising with Electrical Propulsion.

The PPU Mk3 is based on the PPU Mk2 heritage (itself derived from the PPU Mk1) but features additional optimizations to reduce cost and take advantage of the single cathode configuration and independent magnet of most 5 kW class thrusters.

The PPU Mk3 anode supply was first consolidated by a successful coupling test of the 5kW Anode supply and Filter Unit breadboards in October 2014.

Then, a Demonstration Model (DM) of the PPU Mk3, fully representative of the EQM, has been built and has been successfully validated by coupling test with the SPT140-D thruster from Fakel in May 2015, with the PPS-5000 thruster from Safran in October 2015 and with the XR-5 thruster from Aerojet Rocketdyne in December 2015.

The PPU Mk3 EQM has undergone its qualification tests which have included thermal vacuum tests, pressure increase test (corona) and a full EMC test campaign. After the Qualification Review successfully held in March 2016, the PPU Mk3 EQM has been coupled with a SPT140-D thruster, in May 2016 and with a PPS-5000 thruster in February 2017.

In September 2017, nine PPU Mk3 flight models have already been delivered from a total of twenty five PPU Mk3 flight models ordered by three customers.

After the presentation of TAS-B experience in Electric Propulsion, the PPU Mk3 product is described, with its development, coupling tests and qualification.

## II. TAS-B EXPERIENCE IN ELECTRIC PROPULSION

Since 1996, Thales Alenia Space Belgium designs, develops and produces Power Processing Unit (PPU) to supply Hall Effect Thrusters.

The first PPU Mk1 qualification model (Fig. 1), developed for the 50V bus Stentor program, has supplied during 8900 hours an SPT-100 thruster in a vacuum chamber simulating space environment.

Qualified for the 100V Spacebus 4000 platform, the 100V PPU Mk1 and Filter Unit (FU) EQM have cumulated 6300 hours ground operation with a PPS1350-G thruster.

Thirty five PPU Mk1 flight models were delivered to Airbus DS, ESA, IAI, OHB, Safran, TAS-F.

In October 2005, the Smart-1 spacecraft reached the Moon after 4958 hours of cumulated operation of the PPU and its PPS1350-G thruster.

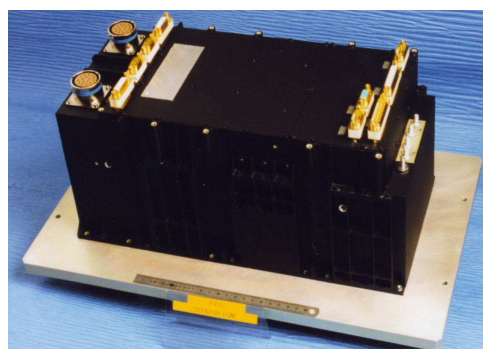

**Figure 1. Stentor PPU Mk1 EQM**

<sup>1</sup> PPU Product Line Manager, Space Business Line, eric.bourguignon@thalesaleniaspace.com

<sup>2</sup> Design Authority for the PPU Product Line, Space Business Line, stephane.fraselle@thalesaleniaspace.com

Twenty four PPU Mk1, currently in flight for North South Station Keeping on twelve telecom satellites, have cumulated more than 39 200 hours flight operation in September 2017.

For the SmallGEO platform, TAS-B has developed and qualified an External Thruster Selection Unit (ETSU) to select one out of four thrusters. Two ETSU flight models were delivered, associated with the PPU Mk1 flight models.

In the frame of AlphaBus extension program and in partnership with ADS and TAS-F, TAS-B has developed the PPU Mk2 product (Fig. 2). The PPU Mk2 addresses PPS1350-G, PPS1350-E, SPT-100 and Hall Effect Thrusters up to 2.5kW for 100V platforms. Taking benefit of the flight experience of the PPU Mk1, the PPU Mk2 provides 1.6 times more output power (1.5kW → 2.5kW) and more flexibility to thrusters and platforms, with reduced manufacturing cost. Qualified in July 2014, the PPU Mk2 EQM was successfully coupled with the PPS1350-G at 1.5kW, the PPS1350-E at 2.5kW and the SPT-100. The first PPU Mk2 flight model is delivered from a total of ten PPU Mk2 flight models ordered by two customers.

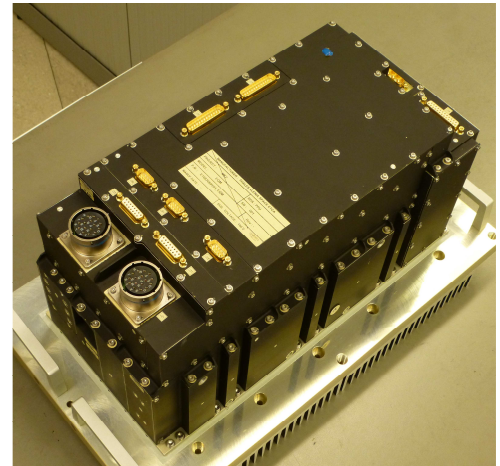

Figure 2. PPU Mk2 EQM

### III. PPU MK3 OBJECTIVES

The objective of the PPU Mk3 development was to capitalize on the PPU Mk2 product to propose a cost-optimized solution with a reduced time to market to drive 5 kW-class thrusters. These high power thrusters will enable an electrical orbit raising of telecom satellites.

The PPU Mk3 objectives were:

- Competitive product,
- Dedicated to PPS-5000, SPT140-D, XR-5 thrusters.
- Dedicated to SpaceBus Neo, Eurostar 3000, NeoSat and Electra platforms.
  - o Bus voltage: 100V regulated
  - o MIL-STD-1553B interface
- Qualification and first flight models in 2016

### IV. PPU MK3 DESCRIPTION

The PPU Mk3 features all the supplies required to operate a Hall Effect Thruster which features a single cathode and a magnet coil independent from the discharge. It also features a switching function which enables to operate one out of two thrusters. It communicates with the satellite platform through a 1553 bus and receives its power from a 100V bus.

Fig. 3 presents the functional diagram of the PPU Mk3.

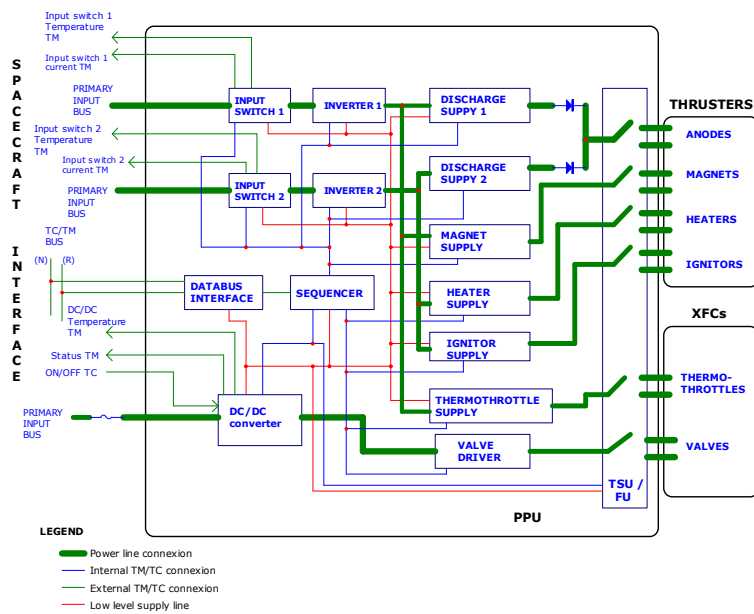

Figure 3. PPU Mk3 Functional Diagram

The main functions of the PPU are:

- 1553 data bus interface to communicate with the satellite.
- DC/DC converter which enables to supply the low-level circuits of the PPU. This DC/DC must be fused protected.
- Sequencer, which is implemented by a FPGA and which controls and monitors all the PPU supplies. The sequencer features an automatic mode where the sequencing of all the supplies is managed to start-up the thruster and operate it in steady mode. Telemetry based protections are also implemented in the FPGA. The sequencer includes a PROM which contains default values and valid ranges to operate different types of thrusters. Standard start-up or soft-start start-up sequence where the cathode is ignited and kept in sustain before applying the anode voltage to reduce inrush current may be selected. The sequencer also implements the regulation loop of the discharge current by controlling the setting of the thermothrottle supply.
- Input switch protections (one for each discharge supply) which enables to avoid any failure propagation to the satellite 100V bus in case of an internal failure.
- Two inverters with their transformer provide the insulated voltages required for the thruster. The inverter is a resonant topology in order to optimize the efficiency.
- Two discharge supplies operate in parallel with their outputs summed by diodes. They provide the anode voltage which is commandable from 100V up to 400V. The discharge supplies implement a power limitation: once the knee-current is reached, the voltage drops linearly as the current increases as presented in Fig. 4 which shows the anode supply characteristic. The short-circuit current is commandable up to 22A. The anode supply, based on two modules of 2.5kW connected in parallel, delivers up to 4.74 kW. The power limitation is required because when the plasma forms at thruster ignition, it drains a lot of current. The linear increase of the current as the voltage decreases is required in order to avoid a lock-up with the thruster characteristic.

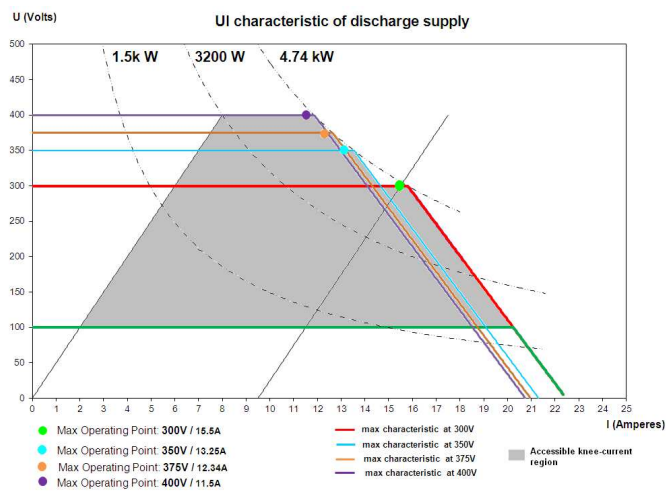

Figure 4. U-I characteristics of the Anode Supply

- Magnet supply drives the thruster magnet coils independent from the discharge, with current up to 7A.
- Cathode heater supply current capacity is 18A.
- Thermothrottle supply providing a current which enable to regulate the Xenon flow.
- The valve driver enables to control the XFC valves.
- The switching unit is relay-based and enables to supply two different thrusters, one at time.
- Two Filter Units are implemented inside PPU Mk3, downstream the TSU. This filter enables to limit the voltage ripple at PPU output due to the thruster noise. Indeed, when the thruster is fired, it generates significant noise. A telemetry providing an image of the thruster noise RMS current value is implemented.

The PPU Mk3 is robust to abnormal pressure increased inside satellite up to 1Pa, by mechanical design.

The mass of the PPU Mk3 that includes TSU and two FUs is 18.6 kg. Its dimensions are 390x320x263 mm<sup>3</sup> (LxWxH).

The PPU Mk3 most dissipative functions are located as close as possible to the baseplate for cooling purpose. The two anode modules include the input switch protections and the main transformer and inverter. The HI module features the heater and ignitor supplies and the MT module contains the magnet and thermothrottle supplies. These four modules are plugged into the Backplane module which features the sequencer, including the communication to the platform and the DCDC. The TSU/FU module comes on top and includes the switching relays necessary for thruster selection and the filter units.

## V. PPU MK3 DEVELOPMENT

The PPU Mk3 development started in 2013, with a Study Phase, to issue and review PPU Mk3 specification with the thruster manufacturers and the primes. The PPU Mk3 architecture was optimized and new packaging was selected to reduce the number of modules and sub-assemblies in order to propose more competitive product. This phase was concluded in January 2014 with the issue of the Technical Requirement Document which is the input for the following phase, the PPU Mk3 Development Phase.

During this phase, a 5kW anode and FU breadboard were coupled with a SPT140-D thruster, in Fakel facilities, at Kaliningrad, Russia, in October 2014, in order to secure the interfaces with the thruster.

By powering the thruster up to 400V and 4.7kW, the anode supply output characteristics and output impedance were validated. The implementation of the FU inside the PPU Mk3 was also validated by testing different harness lengths between PPU, FU and thruster. With these results, the PDR was successfully closed in November 2014.

After the PDR, the PPU Mk3 Demonstration Model (Fig. 5), representative of future flight model (fit, form and function) was developed, manufactured and tested with representative load simulating the thruster and XFC.

The modules of the DM were first tested independently and then assembled. The objective of the DM was to validate the design, including the PCB routing, in a mechanical assembly representative of the flight models. This was important to validate as early as possible that there were no internal EMC issues.

The testing of the DM also enabled to validate the FPGA which controls and monitors all the PPU supplies.

The DM was tested in hot and cold conditions at ambient pressure to validate the good operation of all functions within a wide temperature range as well as to validate the thermal management of the unit. The dissipations in different representative conditions were also measured to check that they were inferior to the worst case computations. The efficiency was measured typically above 95% (Fig. 6). The anode supplies of the PPU Mk3 DM were tested up to 5.2 kW to demonstrate margin on the maximum output power.

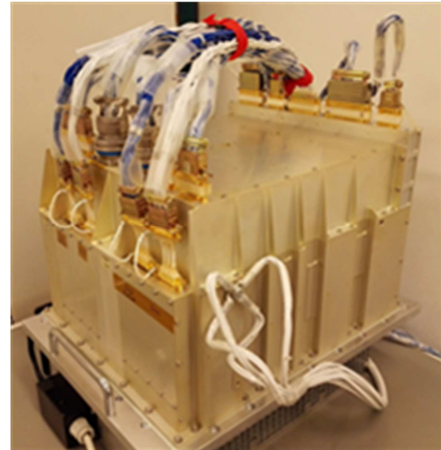

Figure 5. PPU Mk3 DM

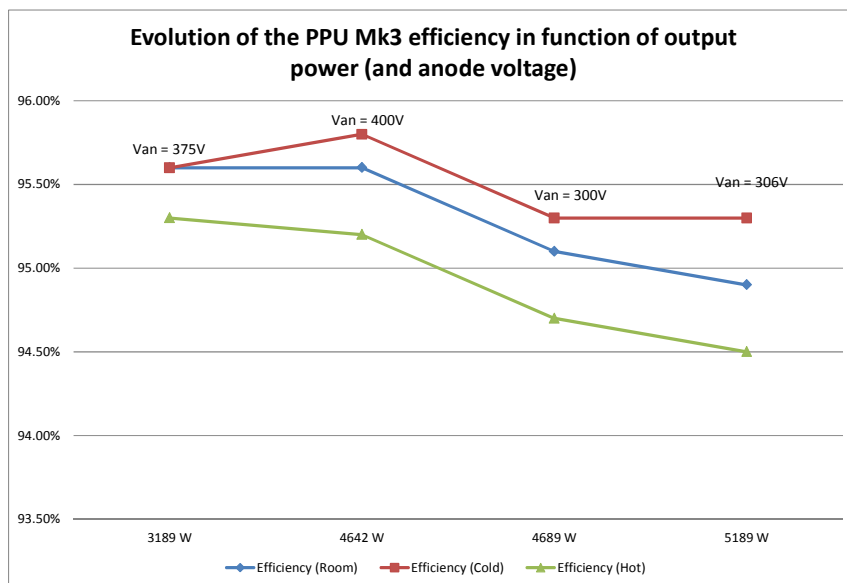

Figure 6. PPU Mk3 DM Efficiency



Another objective of the DM was to provide a representative equipment to validate the Automatic Test Equipment and its test sequence code. The development phase indeed included the implementation of automatic test sequences to implement production tests.

In May 2015, the PPU Mk3 DM has been successfully coupled with a SPT140-D thruster at Aerospazio facilities, in Italy, in partnership with ADS. During that test, the PPU also operated the XFC and its FPGA efficiently regulated the discharge current by controlling the thermothrottle current. This validation test launched the definition and manufacturing of the PPU Mk3 EQM which was anticipated before the CDR, successfully closed in September 2015, in order to reduce the development planning.

In October 2015, the PPU Mk3 DM was also successfully coupled with a PPS-5000 thruster at Pivoine facilities in CNRS Orléans, France.

In December 2015, the PPU Mk3 DM was also successfully coupled to an XR-5 thruster (without XFC) in the frame of an ESA contract led by European Space Propulsion (ESP) as well, at QinetiQ facilities in Farnborough, UK. This test involved experts from ESP, Aerojet Rocketdyne, Mars-Space and TAS-B.

## VI. PPU MK3 QUALIFICATION AND FM's

The PPU Mk3 EQM (Fig.7) was submitted to a full qualification campaign.

The qualification tests first covered the mechanical environment: sine and random vibrations were applied and pyro shocks were performed along all three axis.

The thermal and pressure conditions were validated during the thermal-vacuum test campaign as the EQM was submitted to three cold starts and 9 thermal cycles in vacuum conditions. At the beginning and at the end of the TVAC tests, a pressure increase test up to 2 Pa was performed to demonstrate that the PPU Mk3 is robust to an external pressure increase which can cause Paschen discharges in high voltage equipments.

The PPU Mk3 EQM was then submitted to a full EMC campaign including different LISN configurations to cover different platforms. The equipment conducted emissions were fully characterized both in differential and common modes. Conducted susceptibility tests were also performed to check the good behaviour of the unit in case of bus transient and with injections simulating the thruster worst-case noise. The radiated emissions were measured and radiated susceptibility tests were implemented. Direct ESD tests were performed on the PPU thruster outputs to check that they are robust to an electrical discharge occurring on the electrodes of the thruster. Bundle and ground plane ESD tests were also performed with success.

After the Qualification Review successfully held in March 2016, the PPU Mk3 EQM has been coupled with a SPT140-D thruster at Aerospazio facilities, in May 2016 and with a PPS-5000 thruster at CNRS facilities, in February 2017. In September 2017, a total of twenty five PPU Mk3 flight models have been ordered by three customers. Nine PPU Mk3 flight models have already been delivered from which three PPU Mk3 are in-flight since June 2017, on the first European satellite performing Orbit Raising with Electric Propulsion.

## VII. PPU MK3 VARIANT FOR XR-5

Similarly to PPU Mk1 and Mk2, the PPU Mk3 supplies the thermothrottle of the Xenon Flow Controller to adjust the thruster xenon flow. The thruster discharge is regulated by the PPU sequencer through control of the thermothrottle supply. As the XR-5 thruster is currently qualified with proportional valves (PFCV) instead of thermothrottle to adjust the xenon flow, TAS-B has performed, with ESP, a Neosat pre-development activity to validate TAS-B PPU Mk3 capacity to supply and regulate a Proportional Valve. TAS-B has developed and manufactured a breadboard model, that was coupled to a PFCV in November 2015 at ESP/TAS-UK facilities in Belfast, UK. The test setup included a Thruster simulator reproducing the Discharge current, allowing to test the Discharge current regulation control through the PFCV. The coupling test was successfully carried out. The digital



Figure 7. PPU Mk3 EQM

model used for regulation study and optimization was thereby validated. The Discharge current stability, accuracy, response time and overshoot were within required performances.

Thanks to this pre-development and the coupling test of PPU Mk3 DM with XR-5 thruster, the development of a PPU Mk3 variant for XR-5 thruster is secured.

### **VIII. CONCLUSION**

TAS-B has designed, developed and qualified a new PPU Mk3 product dedicated to 5kW-class Hall Effect Thrusters and 100V satellite platforms. The PPU Mk3 took advantage of a strong heritage with the already qualified PPU Mk2 to ensure a short time to market. Cost reduction measures were implemented in the design, mainly in terms of mechanical packaging. The development started in 2013 and the equipment was successfully qualified in March 2016. Coupling tests were successfully performed with the PPS-5000, the SPT140-D and the XR-5 thrusters.

Up to now, a total of 45 PPU (Mk1, Mk2, Mk3) flight models have been delivered by TAS-B from a total of 70 PPU flight models ordered by our customers: Airbus DS, ESA, IAI, ISS, OHB, Safran, TAS-F. These orders demonstrate the confidence our customers in TAS-B experience in Electric Propulsion, based on:

- 8 900 hrs ground coupling test with EQM Stentor
- 6 400 hrs ground coupling test with EQM SB4000
- 4 958 hrs flight operation of SMART-1
- 39 200 hrs in orbit on telecom satellites