

Phase-resolved optical emission spectroscopy of a neutralizer-free gridded ion thruster

IEPC-2017-330

*Presented at the 35th International Electric Propulsion Conference
Georgia Institute of Technology – Atlanta, Georgia – USA
October 8–12, 2017*

James P. Dedrick* and Andrew R. Gibson†

York Plasma Institute, Department of Physics, University of York, YO10 5DD York, UK

Dmytro Rafalskyi‡ and Ane Aanesland§

*Laboratoire de Physique des plasmas, CNRS, École Polytechnique, UPMC Univ. Paris 06 Univ. Paris-Sud,
Observatoire de Paris, Université Paris-Saclay, Sorbonne Universités, PSL Research University,
F-91128 Palaiseau, France*

Abstract: The development of neutralizer-free sources of electric propulsion is of significant interest for increasing lifetime and downscaling size. To achieve this, the *Neptune* gridded-ion thruster concept uses a single radio-frequency (rf, 4 MHz) power source to accelerate ions and electrons in continuous and pulsed beams, respectively. This is achieved through the generation of a direct current (dc) self-bias voltage across the grids for ion acceleration, where electrons are extracted once per rf cycle when the upstream grid sheath collapses. In this study, we use phase-resolved optical emission spectroscopy and measurements of the electron energy probability function (EEPF) and ion energy distribution function (IEDF) to investigate the charged-particle dynamics 100 mm downstream of the thruster exit. Operating in argon at 100 W rf power, the results for increasing dc self bias voltages 50-150 V show that electrons of energy greater than 13.48 eV are accelerated through the grids in an anisotropic beam once per rf cycle as observed using the Ar(2p₁-1s₂) optical emission. The intensity of the optical emission and EEPFs are consistent with increasing fractional power coupling to the grids for increasing self-bias voltage, where the peak ion energy and IEDF are controlled via the combined rf-dc grid voltage.

Nomenclature

V	Grid voltage
V_{sb}	DC self-bias voltage
θ	Retarding field energy analyzer rotation angle
IEDF	Ion energy distribution function
EEPF	Electron energy probability function

*Lecturer, Department of Physics, james.dedrick@york.ac.uk

†Postdoctoral Research Fellow, Department of Physics, andrew.gibson@york.ac.uk

‡Postdoctoral Research Fellow, Laboratoire de Physique des Plasmas, dmytro.rafalskyi@lpp.polytechnique.fr

§Researcher CR1, Laboratoire de Physique des Plasmas, ane.aanesland@lpp.polytechnique.fr

I. Introduction

Electric propulsion concepts that accelerate equal quantities of positively and negatively charged particles have received significant interest in recent years¹. Their implementation could decrease overall complexity through removal of the space-charge neutralizer, and assist with the development of more compact and longer lasting designs. However, challenges remain in increasing their performance to approach that of established technologies such as Hall effect thrusters^{2,3}.

In the *Neptune* gridded-ion thruster concept, a single radio-frequency (rf) generator is used to couple power to an inductively coupled plasma source (ICP) and one ion-extraction grid, while a second, adjacent grid is electrically grounded⁴. Due to the resultant difference in their surface areas in contact with the plasma, there exists an asymmetry in the sheath capacitances of the two grids. This produces a direct current (dc) self-bias voltage, and the corresponding electric field can be used to accelerate ions. The sheath voltage approaches zero once per rf voltage cycle, and during this interval electrons are accelerated through the grids in pulses to create a charge-neutral flowing plasma⁵.

Neptune generates two distinct beams of charged particles: a continuous, low-divergence ion beam and a pulsed, anisotropic electron beam. Of key importance is the interaction between these two beams. While electrical probe diagnostics have been applied extensively to characterize the beam dynamics in detail⁵⁻⁷, it is experimentally challenging to ensure that these do not interfere with the plasma itself.

Phase-resolved optical emission spectroscopy (PROES) is non-invasive and useful for measuring spatially resolved plasma behavior on nanosecond time scales^{8,9}. Through the selection of appropriate spectral lines, PROES enables the temporal behavior to be measured with respect to electron energy and spatial location, and is therefore complementary to the previously developed electrical diagnostics such as rotating ion and electron energy analyzers⁶. It has previously been applied to investigate the *Neptune* beam dynamics when the extraction grids are driven with rf power as compared to dc power, i.e. in a similar fashion to established gridded-ion thrusters¹⁰.

In this work, we apply PROES, Langmuir probe and retarding field energy analyzer diagnostics to investigate how the the anisotropic, pulsed-periodic propagation of energetic electrons through the extraction grids and the resultant plasma beam dynamics can be controlled via the dc self-bias grid voltage.

II. Experimental setup

The *Neptune* gridded-ion thruster consists of an inductively coupled plasma source (ICP: Teflon-insulated $8 \times 12 \times 12$ cm³ cavity, ferrite-enhanced 7-turn planar antenna driven at 4 MHz, 2 mm thick ceramic window) operated in H-mode and two rectangular extraction grids (stainless steel, optical transparency 0.6, aperture diameter 2.5 mm, inter-grid distance 2 mm). The configuration of the plasma source and diagnostic setup is shown in Fig. 1.

For all experiments, 100 W rf power at 4 MHz is coupled between the amplifier, matching network and *Neptune* plasma source. To investigate the role of the dc self-bias voltage, the configuration of the impedance matching system is optimized such that constant power is coupled to the ICP, while the rf voltage applied at the extraction grids is regulated such that the self-bias voltage varies between $50 < V_{sb} < 150$ V.

The instantaneous voltage measured at the upstream extraction Grid 1, V , is measured with a high-voltage probe and a representative trace is shown in Fig. 2. For a peak-to-peak voltage of 300 V a time-averaged dc self-bias voltage is generated across Grid 1 and Grid 2, i.e. $V_{sb} = 150$ V. As described in detail previously⁵, it is expected that electrons will propagate downstream from the source into the diffusion chamber when $V \sim 0$ V, and these can be accelerated in the field generated during the collapse of the Grid 1 sheath¹¹.

It is important to note that as the rf driving frequency of 4 MHz is comparable to the ion-plasma frequency under these conditions⁵, it cannot be assumed that the ions are only influenced by V_{sb} as is described later in the analysis of the IEDFs.

To demonstrate operation under low-pressure conditions, *Neptune* is connected to a plasma-propagation chamber (1 m long, 0.7 m diameter, 2500 L/s pumping rate) and the argon feed gas flux is regulated such that the pressures in the source and diffusion regions are 1.5 mTorr and 0.2 mTorr, respectively.

An intensified charge coupled device camera (ICCD: *Andor iStar 320 T*, 1024×256 pixel array, $26 \mu\text{m}^2$ pixel area, spatial resolution 26.7 pixel/mm) with interference filter (central wavelength 750 nm, FWHM 10 nm) is used to detect the spectrally resolved optical emission for the Ar($2p_1$ - $1s_2$) line at 750.4 nm. Measurements

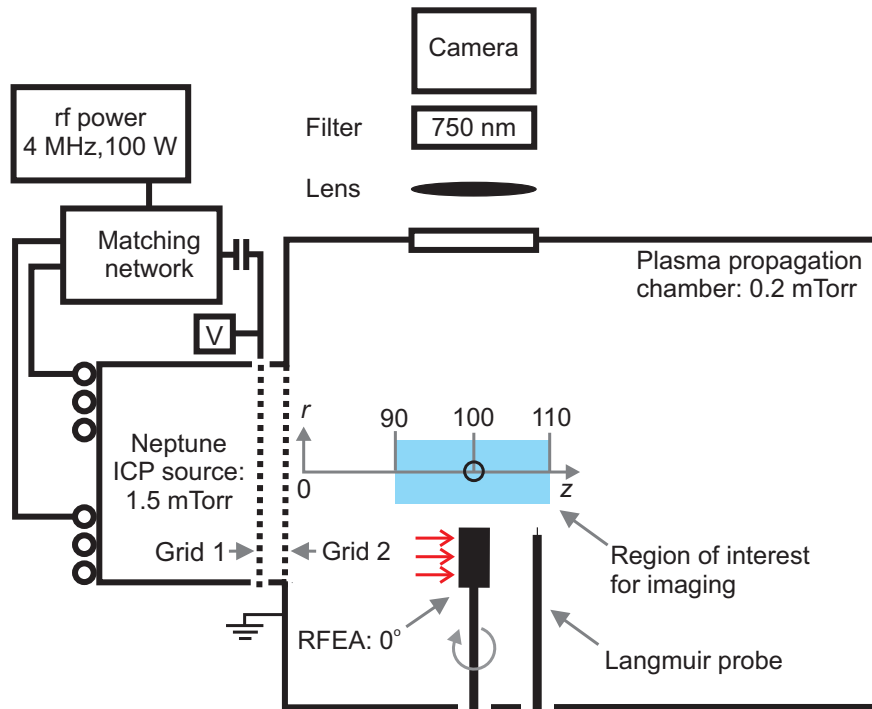

Figure 1: Illustration of the experimental setup. For electrical measurements the Langmuir probe and retarding field energy analyzer (RFEA) are positioned at $(r, z) = (0, 100)$ mm as shown by the open circle, and these are removed for measurements of the optical emission. Adapted from Dedrick *et al* 2017 *Phys. Plasmas* [24 050703](#).

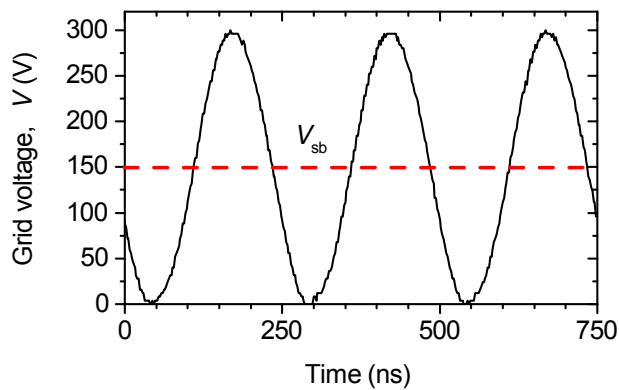

Figure 2: Representative rf voltage V applied at the extraction grids to generate a dc self-bias ion-acceleration voltage $V_{sb} = 150$ V as indicated by the dashed line. Three cycles of the 4 MHz driving voltage are shown.

are undertaken using a 50 ns gate width and a 50 ns gate step. Images are acquired with a sampling frequency of 500 kHz for an exposure time of 20 s and hence the optical emission is integrated over thousands of rf cycles to represent steady-state operation.

If the population of the Ar($2p_1$) level via cascade processes from higher levels is assumed to play a relatively minor role under these conditions¹², it is reasonable to suggest that the detected optical emission is indicative of electrons with energy greater than 13.48 eV for direct-impact excitation of the Ar($2p_1$) level. However, it is important to note that while the emission of interest is out of the Ar($2p_1$) level optical emission from Ar($2p_5-1s_4$) at 751.5 nm is also collected. Since we cannot exclude the optical emission at 751.5 nm in the present experimental setup, and since the Ar($2p_5$) level is known to be more strongly populated by cascade processes from higher levels than the Ar($2p_1$) level¹² the contribution from cascade processes cannot be fully neglected. This is expected to increase in the effective lifetime of the measured optical emission.

The time-averaged electrical properties of the beam are measured downstream at $(r, z) = (0, 100)$ mm and compared with the radially averaged, rf phase-resolved optical emission for $90 < z < 110$ mm. The electron energy probability function (EEPF) is measured using two methods: (1) Langmuir probe (LP) for relatively low-energy isotropic electrons and (2) rf-compensated retarding field energy analyzer (RFEA)^{6,7} to detect the behavior of relatively energetic and directed electrons in the beam (0° rotation angle) and also those that are isotropic (90° rotation angle).

EEPFs are generated from the RFEA measurements by applying a fitting coefficient such that a certain continuity is achieved between the low-energy measurements from the Langmuir probe and the RFEA for which the probe is facing into the beam (0° rotation angle). The value of this coefficient is found to be virtually identical across all measurements.

To determine the ion energy distribution function (IEDF), an RFEA is separately positioned at the same location as for the EEPFs and oriented to be facing the thruster beam (0° rotation angle).

III. Results and discussion

EEPFs measured using the Langmuir probe and RFEA are shown in Fig. 3. For increasing values of V_{sb} of (a) 50 V, (b) 100 V and (c) 150 V, the fraction of the total rf power coupled to Grid 1 increases. Under these conditions, the EEPF of relatively low-energy (less than 14 eV), isotropic electrons measured using the Langmuir probe is observed to broaden. This is accompanied by an increase in the average energy of relatively high-energy (greater than 8-19 eV), isotropic electrons measured using the RFEA orientated at 90° .

The relatively high energy electrons (10-24 eV), which are measured using the RFEA orientated at 0° , are not observed to vary significantly with respect to their maximum energy for increasing dc self-bias voltage $50 < V_{sb} < 150$ V as shown in Fig. 3 (a)-(c).

In a similar fashion to the EEPFs, IEDFs measured in the thruster beam are shown in Fig. 4 for V_{sb} equal to (a) 50 V, (b) 100 V and (c) 150 V. In all cases, the peak ion energy is observed to correlate closely with V_{sb} . For relatively large values of the dc self-bias voltage, the broadening of the IEDF increases and a multi-peaked structure becomes increasingly apparent for Fig. 4 (b) $V_{sb} = 100$ V and Fig. 4 (c) $V_{sb} = 150$ V. As described above, this can reasonably be attributed to the similarity of the rf-driving voltage and ion-plasma frequencies. This means that the ions are effectively controlled by a combined rf-dc voltage, the influence of which becomes increasingly significant as more rf power is coupled to Grid 1.

The rf phase-resolved optical emission is shown in Fig. 5 with respect to increasing dc self-bias voltages (a) 50 V, (b) 100 V and (c) 150 V. As is consistent with the measured EEPFs (Fig. 3) electrons with energy greater than 13.48 eV are observed to propagate in the axial direction away from the thruster once per rf cycle (250 ns rf period at 4 MHz). For all dc self-bias voltages investigated, a sharp decrease in the time-averaged optical emission is observed for $90 < z < 97$ mm. For increasing self-bias voltage the intensity of the time-varying optical emission increases for $97 < z < 110$ mm. As described previously¹⁰, this increase in the optical emission once per rf cycle is caused by the propagation of electrons into the diffusion region when the Grid 1 sheath collapses for $V \sim 0$ V. As a significant change in the high-energy ‘beam’ electron energy probability function is not observed for the measured range of V_{sb} , it is reasonable to suggest that the increase in optical emission can be attributed to an increased electron density for increasing fractional rf power coupling to Grid 1. This is consistent with the increase in the isotropic electron density above 13.48 eV, observed from the measurements of the RFEA orientated at 90° .

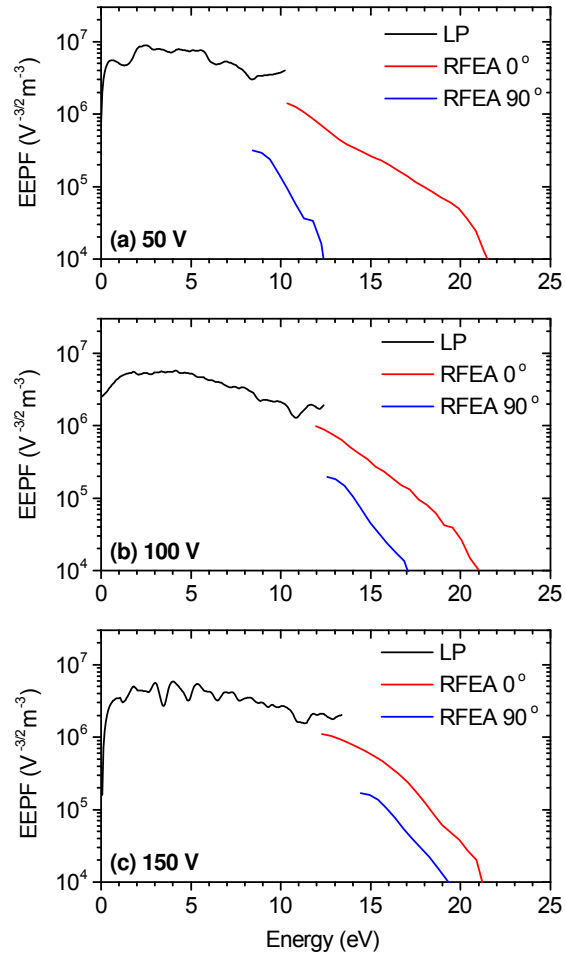

Figure 3: Electron energy probability functions (EEPFs) for dc self-bias voltages V_{sb} equal to (a) 50 V, (b) 100 V and (c) 150 V.

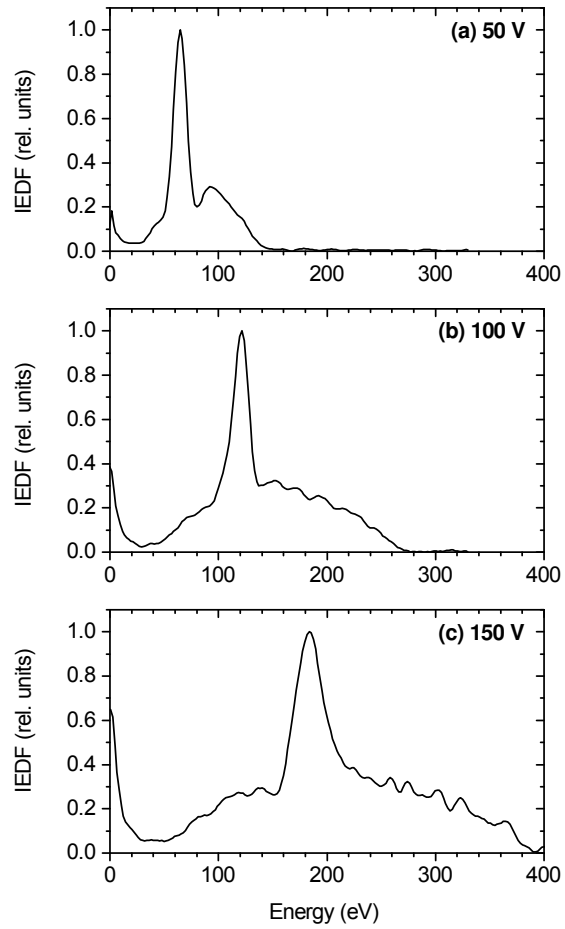

Figure 4: Ion energy distribution functions (IEDFs) for dc self-bias voltages V_{sb} equal to (a) 50 V, (b) 100 V and (c) 150 V.

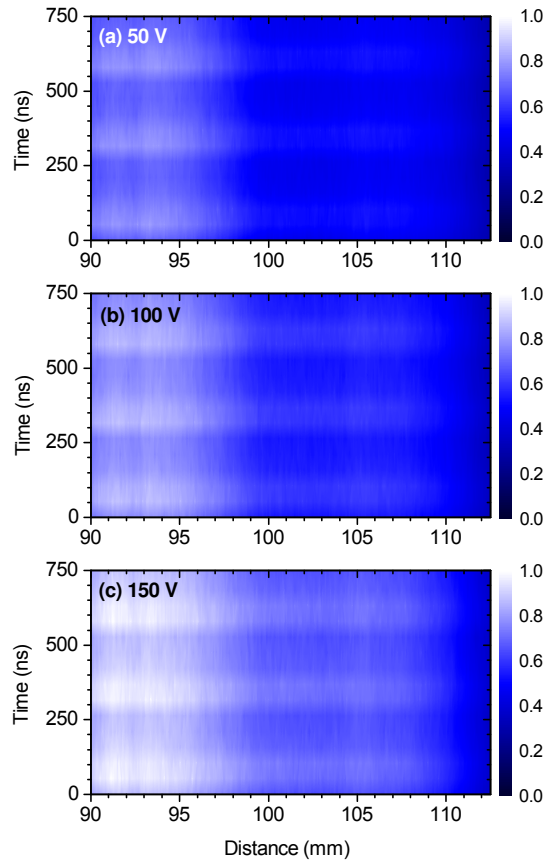

Figure 5: Intensity of the optical emission for dc self-bias voltages V_{sb} equal to (a) 50 V, (b) 100 V and (c) 150 V. Electrical measurements are undertaken at $z = 100$ mm.

IV. Conclusion

In conclusion, beam dynamics of the rf-driven *Neptune* gridded-ion thruster have been investigated using measurements of the phase-resolved optical emission, electron energy probability function (EPPF) and ion energy distribution function (IEDF) with respect to increasing dc self-bias voltage at the extraction grids. Operating in argon at 100 W rf power (4 MHz), the fractional power distribution between the inductively coupled plasma source and grids is optimized to generate dc self-bias voltages of 50-150 V to accelerate ions and electrons in continuous and pulsed beams, respectively. The rf phase-resolved optical emission and EPPFs are consistent with increasing power deposition to the grids for increasing dc self bias voltage, where electrons with energy greater than 13.48 eV propagate in the thruster beam once per rf cycle to underpin space-charge neutralization. This demonstrates the capability to generate and control a flowing plasma beam using a combined rf-dc grid voltage, and thereby effectively generate thrust without the need for a neutralizer.

Acknowledgments

We wish to thank T. Lafleur and T. Gans for useful discussions and the York-Paris CIRC for financial assistance. This work has been done within the LABEX Plas@Par project, and received financial state aid managed by the “Agence Nationale de la Recherche”, as part of the Programme d’Investissements d’Avenir” under the reference ANR-11-IDEX-0004-02. It was also supported by a Marie Curie International Incoming Fellowship within the 7th European Community Framework (NEPTUNE PIIF-GA-2012-326054).

References

- ¹ D. Rafalskyi and A. Aanesland. Brief review on plasma propulsion with neutralizer-free systems. *Plasma Sources Science and Technology*, 25(4):043001, 2016. doi:[10.1088/0963-0252/25/4/043001](https://doi.org/10.1088/0963-0252/25/4/043001).
- ² D. M. Goebel and I. Katz. *Fundamentals of Electric Propulsion*. Hoboken, USA: Wiley, 2008.
- ³ C. Charles. Plasmas for spacecraft propulsion. *Journal of Physics D: Applied Physics*, 42(16):163001, 2009. doi:[10.1088/0022-3727/42/16/163001](https://doi.org/10.1088/0022-3727/42/16/163001).
- ⁴ D. Rafalskyi and A. Aanesland. *French Patent Application: Dispositif de formation dun faisceau quasi-neutre de particules de charges opposées*, 14 53469, 2014.
- ⁵ D. Rafalskyi and A. Aanesland. Coincident ion acceleration and electron extraction for space propulsion using the self-bias formed on a set of RF biased grids bounding a plasma source. *J. Phys. D: Appl. Phys.*, 47(49):495203, 2014. doi:[10.1088/0022-3727/47/49/495203](https://doi.org/10.1088/0022-3727/47/49/495203).
- ⁶ D. Rafalskyi and A. Aanesland. Plasma acceleration using a radio frequency self-bias effect. *Phys. Plasmas*, 22(6):063502, 2015. doi:[10.1063/1.4922065](https://doi.org/10.1063/1.4922065).
- ⁷ D. Rafalskyi and A. Aanesland. Characterization of a neutralizer-free gridded ion thruster. In *34th International Electric Propulsion Conference and 6th Nano-satellite Symposium*, 2015.
- ⁸ J. Schulze, E. Schüngel, Z. Donkó, D. Luggenhölscher, and U. Czarnetzki. Phase resolved optical emission spectroscopy: a non-intrusive diagnostic to study electron dynamics in capacitive radio frequency discharges. *Journal of Physics D: Applied Physics*, 43(12):124016, 2010. doi:[10.1088/0022-3727/43/12/124016](https://doi.org/10.1088/0022-3727/43/12/124016).
- ⁹ T. Gans, D. O’Connell, V. Schulz-von der Gathen, and J. Waskoenig. The challenge of revealing and tailoring the dynamics of radio-frequency plasmas. *Plasma Sources Science and Technology*, 19(3):034010, 2010. doi:[10.1088/0963-0252/19/3/034010](https://doi.org/10.1088/0963-0252/19/3/034010).
- ¹⁰ J. Dedrick, A. R. Gibson, D. Rafalskyi, and A. Aanesland. Transient propagation dynamics of flowing plasmas accelerated by radio-frequency electric fields. *Physics of Plasmas*, 24:050703, 2017. doi:[10.1063/1.4983059](https://doi.org/10.1063/1.4983059).

- ¹¹ J. Schulze, Z. Donkó, B. G. Heil, D. Luggenhölscher, T. Mussenbrock, Brinkmann P. R., and U. Czarnetzki. Electric field reversals in the sheath region of capacitively coupled radio frequency discharges at different pressures. *Journal of Physics D: Applied Physics*, 41(10):105214, may 2008. doi:[10.1088/0022-3727/41/10/105214](https://doi.org/10.1088/0022-3727/41/10/105214).
- ¹² J. Ethan Chilton, John B. Boffard, R. Scott Schappe, and Chun C. Lin. Measurement of electron-impact excitation into the $3p^54p$ levels of argon using Fourier-transform spectroscopy. *Phys. Rev. A*, 57(1): 267–277, Jan 1998. doi:[10.1103/physreva.57.267](https://doi.org/10.1103/physreva.57.267).