

Engineering Model Development of the Water Resistojet Propulsion System: AQUARIUS for the SLS EM-1 CubeSat: EQUULEUS

IEPC-2017-401

*Presented at the 35th International Electric Propulsion Conference
Georgia Institute of Technology • Atlanta, Georgia • USA
October 8 – 12, 2017*

Jun Asakawa, Keita Nishii, Hiroyuki Koizumi, Naoki Takeda Ryu Funase and Kimiya Komurasaki¹
The University of Tokyo, Bunkyo-ku, Tokyo, 113-8656, Japan

Abstract: In this study, Water micro-propulsion system AQUARIUS (AQUA Resistojet propulsion System) is proposed for 6U CubeSat: EQUULEUS to explore the deep space. AQUARIUS uses storable, safe and non-toxic propellant: water, which allows for downsizing of whole propulsion system to 2U and storing 1.2 kg water. Liquid propellant storage allows design of all propulsion systems below 100 kPa. The waste heat of communication components is reused to cover high latent heat of water. AQUARIUS has 4.0 mN and specific impulse of 70 s by less than 20 W power consumption. Engineering model was fabricated and tested by using whole systems of EQUULEUS. AQUARIUS will be equipped with EQUULEUS scheduled to be launched in 2019 by SLS (Space Launch System).

I. Introduction

In recent years, micro/nano-satellites' missions are diversifying such as re-entry or deep space exploration (Ref. 1-4). Micro-propulsion systems are indispensable for micro/nano-satellites to conduct such missions. Cold gas jet, which structure was simple although thrust performance was low, was often used (Ref. 5-6). Ion thruster and cold gas thruster unified propulsion system "I-COUPS" was developed and demonstrated in deep space (Ref. 7-10). However, there are some problems such as low thrust performance or higher dry mass fraction because of high pressure gas system such as a tank, feed lines and valves. For example, in the case of miniature ion propulsion system "MIPS" developed by the University of Tokyo, 45 % of the total propulsion system with a mass of 10kg were occupied by high pressure gas systems (Ref. 11). Chemical propulsion systems which use hydrogen or AND are also conventional for large satellites. However, utilizing cost of toxic propellant including hardware, operation, ground support infrastructure and transportation will reach to more than \$1M (Ref. 12). Therefore, it is not feasible for micro/nano-satellites. For the next generation micro-propulsion system, three things are required as follows: 1) un-pressurized, 2) safe and easy-handling, 3) multi-function.

The University of Tokyo have been developing a new micro-propulsion system AQUARIUS (AQUA Resistojet propulsion System). AQUARIUS uses storable, safe and non-toxic propellant: water. Liquid propellant storage allows design of all propulsion systems below 100 kPa, reduction of dry mass ratio and simplification of feed line routing using soft tubes. The safety of this system also makes possible short period and low-cost development compared to conventional propulsion systems, because it becomes relatively easier to meet launcher's safety requirements. In addition, water has been arousing interest as a potential resource for future deep space exploration. In the future, the use of water collected in space is likely to be promoted. AQUARIUS has totally 6 thruster-heads. Two of them are for delta-V maneuver (DV thruster), and others are for reaction control to reduce rotation speed of reaction wheels (RCS thruster). AQUARIUS will be equipped with 6U deep space exploration CubeSat: EQUULEUS developed by the University of Tokyo and JAXA (Ref. 13). EQUULEUS is scheduled to be launched in 2019 by SLS (Space Launch

¹ Ph. D. candidate, Department of Aeronautical and Astronautical, j.asakawa@al.t.u-tokyo.ac.jp

System) (Ref. 14). EQUULEUS will fly to the Earth-Moon L2 (EML2) point and conduct missions as follows: 1) trajectory control within a Sun-Earth-Moon region, 2) recording the Earth’s plasma-sphere, 3) characterizing the size, frequency, and distance of celestial bodies in cis-lunar space. Notably, this is the world’s first demonstration of trajectory control techniques within the Sun-Earth-Moon region by a nano-spacecraft, leading to future space missions related to a deep-spaceport. The key technology is the micro-propulsion system AQUARIUS, which is expected to have two propulsion capabilities: 1) reaction control, 2) delta-V maneuver for a lunar flyby and EML2 liberation orbit insertion. The target performances are a thrust of 4 mN, a specific impulse of 70 s, and a delta-V of 70 m/s for 6U CubeSat. To enable insertion into the first lunar flyby orbit, a delta-V of more than 10 m/s is required within the first couple of days after launch. For this mission, a resistojet has been selected for its simple structure and high reliability. What is the most difficult is high latent heat of water, leading to increasing of heater power input to the vaporization chamber.

II. AQUARIUS

Figure 1 shows 3D-CAD model of AQUARIUS. Performance specifications are listed in Table 1. Water propellant mass is 1.2 kg. Total power consumption is less than 20 W. To overcome that difficulty of high latent heat, waste heat generated from communication components is reused by sandwiching the vaporization chamber by them.

Figure 2 shows a system diagram of AQUARIUS. AQUARIUS consists of three main components: a tank, a vaporization chamber, and thruster-heads. Inside the tank, a bladder is inserted, which is a kind of rubber balloon, storing 1.2 kg of water inside. Pressurized gas and water are separated by the bladder. Nominal temperature of the tank is 283-293 K. The vaporization chamber made of aluminum is manufactured by using 3D printing technology. Nominal temperature and pressure of the vaporization chamber are around 293 K and less than 4.0 kPa. The thruster-head consists of three-components: a thermal insulator, a pre-heater and a nozzle. Saturated water vapor is heated to around 393 K at the pre-heater which is also manufactured by using 3D printing technology to make a helical flow path in it. Throat diameter of the RCS nozzle and DV nozzle are around 1.2 mm and 2.0 mm respectively. The orifice diameter of the thruster-valve is 1.6 mm which is smaller than the throat diameter of the DV nozzle, so the flow could be choke at the valve orifice. To increase the mass flow rate without choking at the valve orifice, two parallel thruster-valves are integrated.

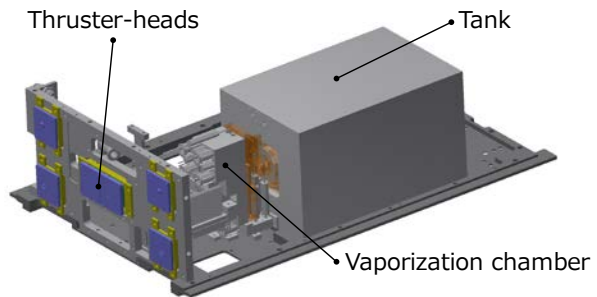

Figure 1. 3D CAD model of AQUARIUS

Table 1. Specifications of AQUARIUS

AQUARIUS	
Propellant	Water (< 100 kPa)
Thrust	4.0 mN
Specific impulse	70 s
Power consumption	< 20 W
Number of delta-V thruster	2
Number of RCS thruster	4
Volume (CubeSat unit)	2.0U

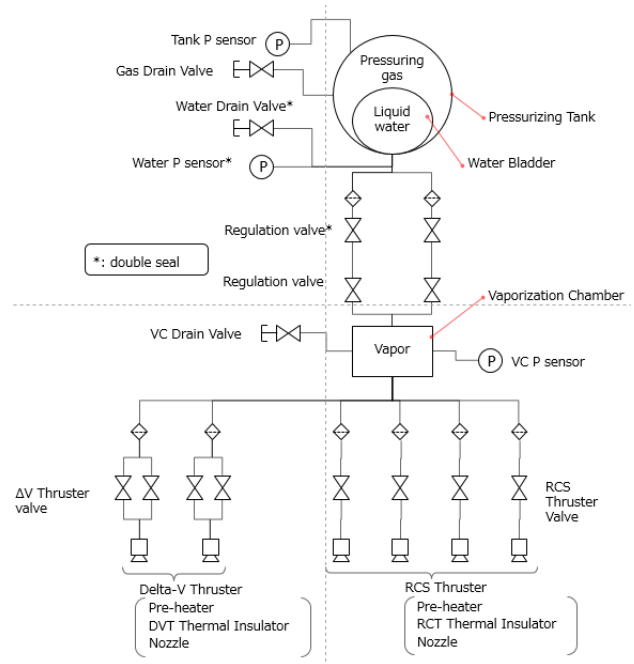

Figure 2. System diagram of AQUARIUS

III. Design and Integration

The tank (97×105×163 mm) made of aluminum was manufactured by cutting and welding. The COTS bladder was inserted inside. Two pressure sensors were integrated to measure the pressure of the tank and the bladder. Regulation valves were integrated just beside the tank. Dry mass was 0.60 kg. The vaporization chamber (30×30×70 mm) made of aluminum was manufactured by using 3D printing technology with a mass of 0.16 kg (Figure 10). Water droplet injection part and flow path were manufactured inside. An electrical heater was embedded in the water droplet injection part. Two pressure sensors were inserted into the vaporization chamber. Eight thruster-valves and six tube fittings were inserted into the vaporization chamber. Thrust-head was connected through a soft tube to each tube fitting. Two DV thrusters were mounted on the panel through a single thermal insulator. Thermos sensors were attached to each thruster-head, soft tube. Soft tube allows for six tube routing in the restricted space. AQUARIUS-EM was integrated on EQUULEUS-EM (Figure 11). The tank and the vaporization chamber were mounted on the panel through the glass epoxy jig for the thermal insulation. The vaporization chamber was sandwiched by the communication components via thermal conducting sheet. Two DV thruster-heads were mounted on the center of the panel and four RCS thruster-heads were mounted on the corner. AQUARIUS-EM was electrically connected via 100 pin D-SUB connector.

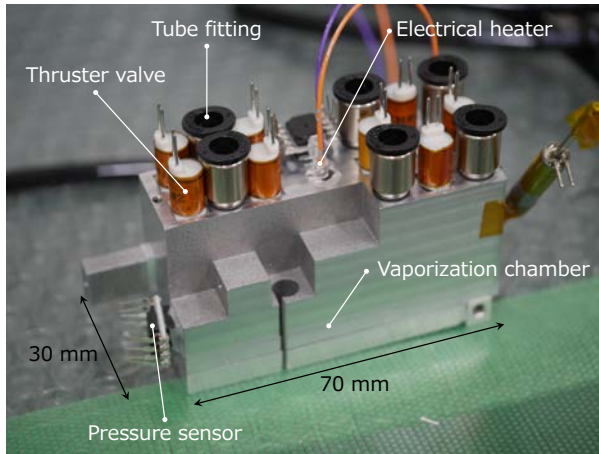

Figure 4. Vaporization chamber - EM

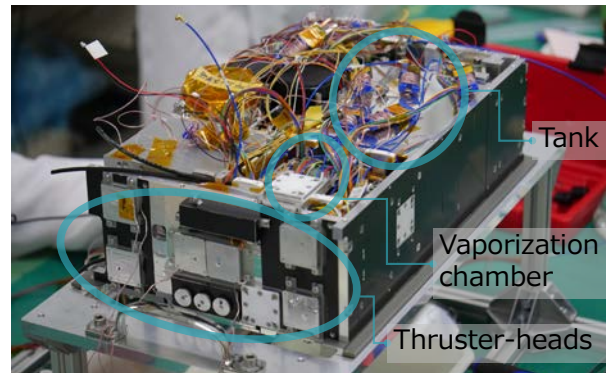

Figure 3. AQUARIUS integrated on EQUULEUS

IV. Operation test

Performance was evaluated by using whole systems of EQUULEUS-EM in the vacuum chamber with a diameter of 2.0 m and a length of 3.0 m. a rotary pump and a diffusion pump were used for vacuuming during the firing. EQUULEUS-EM was mounted on the temperature control plate which can change the temperature with a range of 0 – 60 °C. Figure 13 shows one-hour operation result of the DV thruster. The frequency of valve actuating was 10 mHz. Valve open duration time was 0.50 s. Heater input power of the vaporization chamber was 3.0 – 7.0 W. The vaporization chamber pressure was stable at 1.5 – 2.0 kPa. The vaporization chamber temperature increased during operation because heater input power was increased. The communication component temperature decreased when the operation started, which means that the vaporization chamber and the communication component were thermally coupled. Figure 14 shows the coupling operation of DV and RCS thruster. When both DV thruster and RCS thruster operated, vaporization chamber pressure and temperature decreased because mass flow rate increased. After RCS operation finished, vaporization chamber pressure and temperature recovered because mass flow rate became nominal.

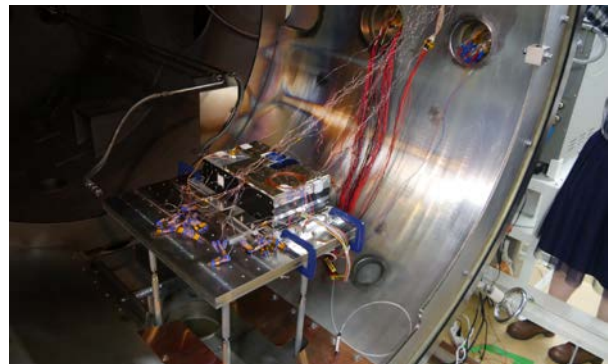

Figure 5. Operation test in the vacuum chamber by using whole systems of EQUULEUS

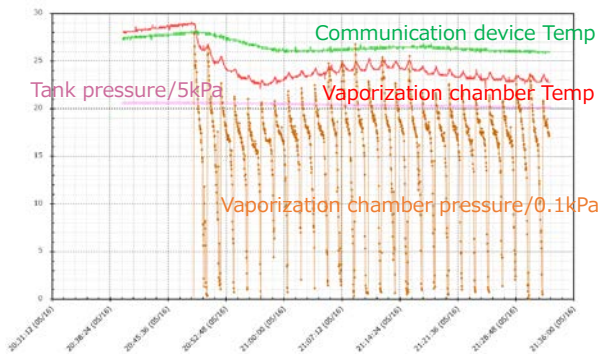

Figure 6. One-hour operation test result of the DV thruster

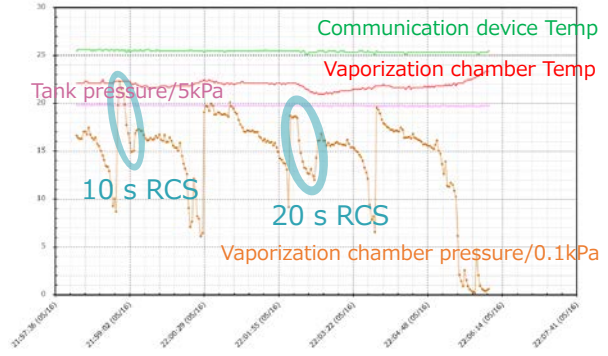

Figure 7. Coupling operation of the DV thrust and RCS thruster

V.Environmental tests

Vibration tests were conducted in three configurations as follows: 1) tank and bladder, 2) thruster-heads, 3) whole system of EQUULEUS-EM. Figure 15 - 17 shows each configuration of the vibration test.

The aluminum tank which one side is made of acrylic was used to observe the behavior of the bladder inserted inside.

The gap between the tank and the bladder was filled with air with a pressure of 100 kPa. As the result, there are no leak of water and no damage to the tank and the bladder. Deformation of the bladder inside the tank was observed.

Two DV thruster-head and two RCS thruster-heads, which designs were similar to EM, were tested. Tube fittings were integrated, although soft tubes are not inserted. Thruster-heads were mounted on the panel which thickness is much thicker than the actual panel. As the result, cracks were observed in the thermal insulator. This is because the glass epoxy has weak strength along to the fiber direction. In flight model, design and material of thermal insulator will be changed. In the vibration test using whole systems of EQUULEUS-EM, one accelerometer was mounted on the RCS nozzle because of restricted space. It was confirmed that all electrical heaters, thermocouples, pressure sensors and valve except for regulation valves operated normally after the vibration test.

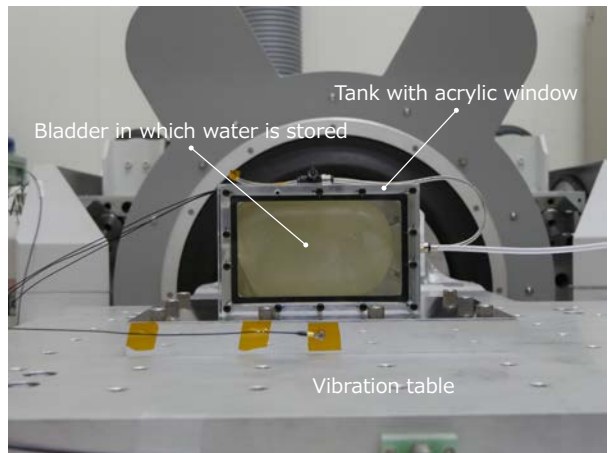

Figure 8. Configuration of the tank and the bladder vibration test

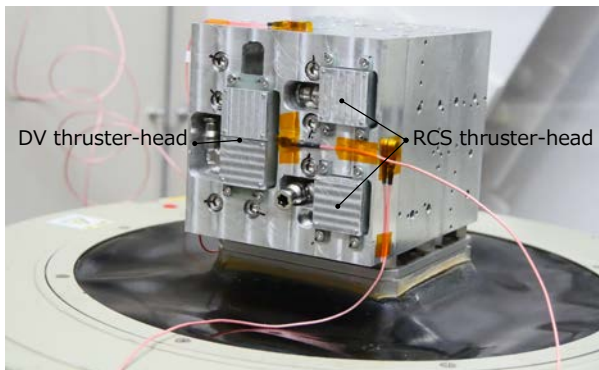

Figure 10. Configuration of the thruster-head vibration test



Figure 9. Configuration of EQUULEUS vibration test

VI. Conclusion

Water micro-propulsion system: AQUARIUS (AQUA ResIstojet propUlsion System) was proposed for 6U deep space CubeSat: EQUULEUS. Required thrust and specific impulse are 4.0 mN and 70 s. 1.2 kg water was stored inside the tank with a dry mass of 0.60 kg. Waste heat of communication component was reused to overcome the problem of high latent heat of water. Vaporization chamber-BBM operated stably for more than one hour with heater input power of 10 W. The measured specific impulse was 30 % lower than the theoretical one. The nozzle theory is not applicable because of the low Reynolds number. EM was designed and manufactured by using guidelines obtained through BBM tests. EM of the vaporization chamber and pre-heater made of aluminum were manufacture by 3D printing technology. AQUARIUS-EM was integrated on EQUULEUS-EM. More than one-hour DV thruster operation and DV thruster and RCS thruster coupling operation were successful. Vibration test of EQUULEUS-EM was finished.

Acknowledgments

This work was supported by JSPS KAKENHI grant: Grant-in-Aid for Scientific Research (S), No. 16H06370.

References

The following pages are intended to provide examples of the different reference types. You are not required to indicate the type of reference; different types are shown here for illustrative purposes only.

¹Schoolcraft, J., Klesh, A., and Werne, T. "MarCO: Interplanetary Mission Development on a CubeSat Scale", SpaceOps Conference, 2016, AIAA 2016-2491.

²Nehrenz, M., and Sorgenfrei, M. "On the Development of Spacecraft Operating Modes for a Deep Space CubeSat", SPACE Conferences and Exposition, 2015, AIAA-2015-4647.

³Tsay, M., Frongillo, J., Hohman, K., and Malphrus, B. K. "LunarCube: A Deep Space 6U CubeSat with Mission Enabling Ion Propulsion Technology", 29th Annual AIAA/USU Small Satellite Conference, 2015, SSC15-XI-1.

⁴Yamada, K., Nagata, Y., Abe, T., Suzuki, K., Imamura, O., and Akita, D., "Suborbital Reentry Demonstration of Inflatable Flare-Type Thin-Membrane Aeroshell Using a Sounding Rocket," Journal of Spacecraft and Rockets, Vol. 52, No. 1, Feb. 2014, pp. 275–284.

⁵Bonin, G., Roth, N., Armitage, S., Newman, J., Risi, B., and Zee, R. E., "CanX-4 and CanX-5 Precision Formation Flight: Mission Accomplished!," 29th Annual AIAA/USU Conference on Small Satellites, Logan, Utah, 2015, SSC07-XI-1.

⁶Bowen, J., Tsuda A., Abel, J., and Villa, M., "CubeSat Proximity Operations Demonstration (CPOD) Mission Update," 2015 IEEE Aerospace Conference, 2015.

⁷Koizumi, H., "Small Propulsion System on the Micro-Space Probe, PROCYON: Stories and Lessons Learned from the Development to the In-Flight Operation," Journal of Plasma Fusion Research, Vol.92, No.7, pp. 501 - 513, 2016 (in Japanese)

⁸Yaginuma, K., Koizumi, H., Kawahara, H., Asakawa, J., Nakagawa, Y., Inagaki, T., Kasagi, Y., Ikari, T., Ozaki, N., Funase, R., and Komurasaki, K., "Thrust Vector Management of Electric Propulsion System for Micro-Spacecraft and Its On-Orbit Validation Results," Journal of the Japan Society for Aeronautical and Space Sciences," Vol. 64, No.2, pp.131-138, 2016 (in Japanese)

⁹Koizumi, H., Kawahara, H., Yaginuma, K., Asakawa, J., Nakagawa, Y., Nakamura, Y., Kojima, S., Matsuguma, T., Funase, R., Nakatsuka, J., and Komurasaki, K., "Initial Flight Operations of the Miniature Propulsion System installed on Small Space Probe: PROCYON," Transactions of Japan Soc. for Aeronautical and Space Sci., Aerospace Technology Japan, Vol. 14, Pb_13-Pb_22, 2016.

¹⁰Funase, R., Inamori, T., Ikari, S., Ozaki, N., Koizumi, H., Tomiki, A., Kobayashi, Y., and Kawakatsu, Y., "Initial Operation Results of a 50kg-class Deep Space Exploration Micro-Spacecraft PROCYON," Small Satellite Conference, SSC15-V-5, 2015

¹¹Koizumi, H. Komurasaki, K., Aoyama, J., and Yamaguchi, K., "Engineering Model of the Miniature Ion Propulsion System for the Nano-satellite," Trans. JSASS Space Tech. Japan, Vol. 12, pp.Tb_19-Tb_24, 2014.

¹²Bombelli, V., Simon, D., Moerel, J., Marée, T., "Economic Benefits of the Use of Non-Toxic Mono-Propellants for Spacecraft Applications," 9th AIAA/ASME/SAE/ASEE Joint Propulsion Conference and Exhibit, 2003, AIAA 2003-4783.

¹³Funase, R., Ikari, S., ozaki, N., Nakajima, S., Oguri, K., Miyoshi, K., Campagnola, S., Koizumi, H. and Kobayashi, Y., "EQUULEUS: Mission to Earth - Moon Lagrange Point by a 6U Deep Space CubeSat" 14th Annual Pre-conference Workshop of 31st Annual AIAA/USU Conference on Small Satellites.

¹⁴Singer, J., Pelfrey, J., and Norris, G. "Enabling Science and Deep Space Exploration through Space Launch System (SLS) Secondary Payload Opportunities," SpaceOps Conference, 2016, AIAA 2016-2585.